

outdoor solutions



6 — 9
about us

10 — 25
**bioclimatic
pergolas**
Santorini PG160P
Mykonos PG120P
Ithaca PG115P

26 — 37
**fixed
pergolas**
Creta
Corfu
Kos
Naxos

38 — 47
**fencing
systems**
FC80
FC60



Explore all of our outdoor
solutions at glm-outdoor.com

outdoor solutions





GLM OUTDOOR SOLUTIONS is the authorized manufacturer of the advanced shading systems (pergolas & fabrics) and fences of ALUMIL, the leading Greek company in the design and production of architectural aluminium systems. GLM has developed and continuously enriches a wide range of holistic and reliable solutions for every type of outdoor space, with composition and full customization possibilities.

Combining top quality with technological innovation and high aesthetics, GLM offers unique products that enhance and upgrade the outdoor environment, promoting a different way of life inspired by the values of natural light and outdoor living freedom and rooted in the principles of sustainability.



about us

Values

GLM's values are its compass, define how the company develops its products and guide its relationships with its customers, people, society and other stakeholders.

Vision

GLM's vision is to cultivate and spread a different culture of living, according to which the inside and the outside coexist harmoniously, and humans are in constant contact with the external environment and live in it with comfort, freedom and respect, upgrading the quality of their daily life.

Mission

GLM's mission is to create unique outdoor living experiences through innovative products of top quality, technology and aesthetics.

Experience Outdoor Living

Experience Outdoor Living. Create modern, comfortable and safe outdoor spaces that protect you from the weather conditions and allow you to enjoy the outdoors all year round. This exhortation is at the core of GLM's philosophy, which is inherent in all of the company's product lines.



Environmental awareness

GLM's profiles supplied by ALUMIL are made of recycled aluminium, and the shading systems are designed to make the most of the weather, ensuring ideal living conditions. Fully aware of the serious environmental problems facing the planet, GLM promotes a more sustainable lifestyle and fosters in its people a culture of responsibility towards the environment.



Innovation

With a focus on people's needs and on the improvement of their quality of life, GLM redefines the concept of outdoor space, reimagines the culture of outdoor living in modern cities and designs innovative systems that transform everyday life into a unique experience.



Integrity

Integrity is a priority for GLM and every decision made is based on strict moral principles, ensuring that they are implemented both by GLM's people and by individuals or organizations associated with and/or collaborating with the company.



Team spirit

A key principle of GLM is that a group of disparate people can be transformed into a close-knit and strong team capable of meeting even the highest demands. Team spirit dominates the way the company operates, the way it works with others, the way it cooperates with others, and the way it faces new challenges.

bioclimatic pergolas

Aiming to create modern and comfortable outdoor spaces that effectively protect from all weather conditions, offering a unique living experience all year round, GLM has designed a series of bioclimatic pergolas with fully automated mobile louvers, ideal for free-standing, wall-mounted and many other constructions in hotels and restaurants, homes, gardens, patios, terraces and any type of outdoor space. Advanced technology, high aesthetics, top quality, absolute reliability, and many customization possibilities with unlimited color options.

These are the key elements of the company's philosophy, which is reflected in all three models of bioclimatic pergolas offered.

Santorini - PG160P



Mykonos - PG120P



Ithaca - PG115P

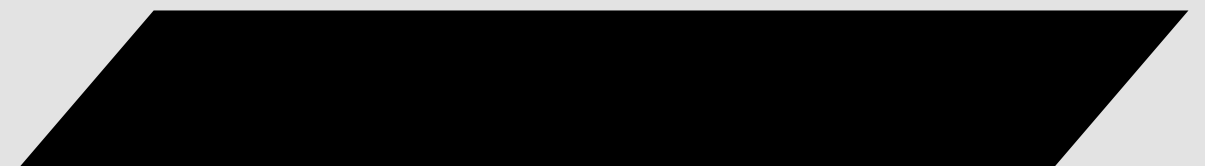

bioclimatic pergolas

Discover the bioclimatic logic.

Thanks to the bioclimatic logic, additional utility elements can be integrated into the pergolas, which extend the interior space to the outside, offering even more freedom and comfort in everyday living all year round.

- Vertical rolling fabric screens or sliding aluminium shutters for additional shading.
- Glass sliding system to create bright, temperature-controlled spaces.
- LED lighting applied on transoms and louvers for atmospheric and stylish lighting at night.
- Heating devices (infra-red).
- Sound systems.
- Sensors for wind, rain, sun.
- Certified systems from the ift Rosenheim Institute.

Top design.

A harmonious combination of high aesthetics and functionality, with clean lines, invisible fixing points and a totally concealed motor. GLM's bioclimatic pergolas are the definition of high-tech minimalism and quality of life enhancement.

Noiseless rotation mechanism.

Totally concealed patented rotation system built into one of the louvers, which offers flawless and silent operation.

Sturdiness and very large dimensions.

Thanks to their impressive robustness, GLM's bioclimatic pergolas cover very large areas, up to 50m² with only four columns, and can withstand very strong winds and high snowfall up to 300Kg/m² (under certain conditions).



bioclimatic pergolas

Solutions with posts.

High levels of watertightness and leakage avoidance.



Effective water drainage system, from top to bottom via the posts, using special rubber components and gutter profiles of large dimensions.



Innovative rotation mechanism, placed inside the louver, with flawless and long-lasting operation.



The modular connection of mullion with transom profiles contributes to the robustness and ease of construction.

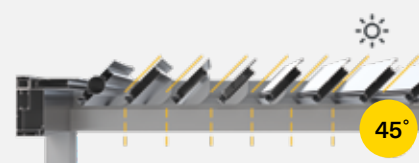
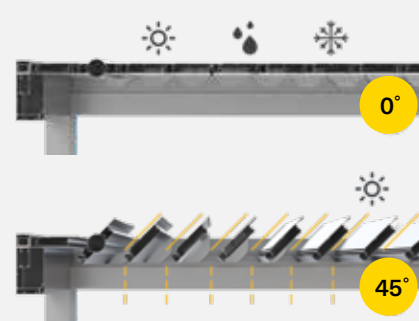
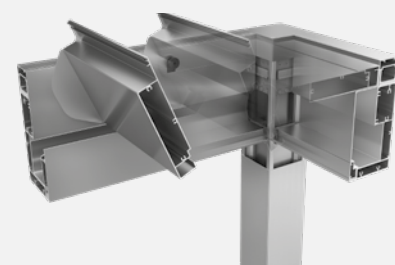

louvers position and effect

Great variety of solutions.

GLM's systems offer multiple construction options that cover every need and complexity.

- Free-standing and wall-mounted construction.
- Single, double, corner, multiple and complicated structures.
- Structures with additional elements such as sliding and shading screens.
- Sliding shutter with louver or fabric.

Integrated water sealing and drainage system.

A design innovation that offers protection against heavy rainfall.

- Efficient sealing along the entire water path, from louvers to ground.
- Protection against possible overflow in the event of heavy rainfall, thanks to the wide gutters and the other profile sections through which the water passes.
- Minimal use of silicone, which guarantees a longer service life.

Ease and speed of installation.

Thanks to their special design, with modular profiles and hook-type accessories, the bioclimatic pergolas can be installed quickly and easily.

SANTORINI is a bioclimatic pergola of top sturdiness, ideal for very large structures up to 7.2x7.2m, which makes it truly unique. In the case of residential buildings, part of a 50m² courtyard can be transformed into a separate space with controlled shading and ventilation, improving the quality of life. In the case of hotels, restaurants and commercial premises, multiple structures can effectively cover very large areas with fewer mullions, allowing a large number of tables to be placed.

Santorini^{PG160P}

the charm of luxury

- Effective protection from sun, rain, snow and other weather conditions.
- Special water sealing system from the louvers to the base of the post, which incorporates an effective water drainage system to protect against overflow due to heavy rainfall.
- Controlled conditions thanks to the adoption of bioclimatic logic and the incorporation of additional elements such as sliding glass and shutter systems, vertical shading screens (ZIP), LED lighting, etc.
- Impressive sturdiness allowing very large dimensions, up to 7.2x7.2m with only four posts.
- State-of-the-art components, such as the invisible patented silent rotation mechanism and automation systems.
- High aesthetics and minimal design with attention to detail.
- Wide range of solutions and possibilities for customization and extension to meet every need.



single wall-mounted

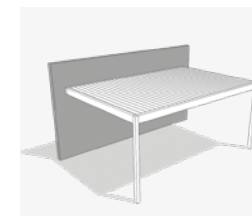

single wall-mounted with intermediate transom

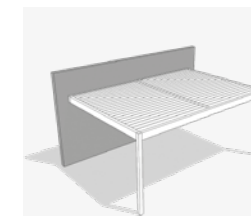

single free-standing

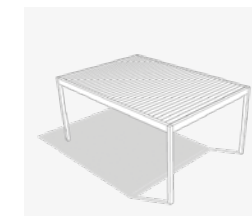

single free-standing with intermediate transom

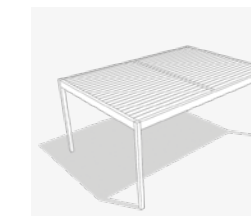

multiple free-standing

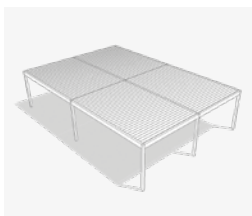

multiple free-standing with intermediate transoms

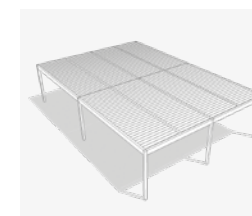

double wall-mounted with intermediate transoms

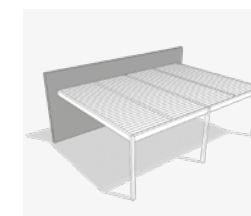

double free-standing

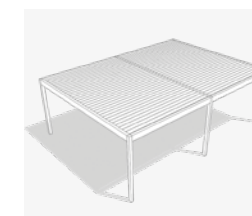

double free-standing with intermediate transoms

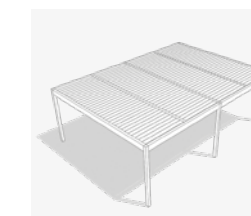

embedded



MYKONOS is more than just a classic pergola option for controlled shading and effective protection against rain, snow and other weather conditions. In addition to its functionality, it is characterized by its absolutely minimal aesthetics and top sturdiness, enabling elegant and large structures up to 6.5x4.5m or 6.2x4.2m in the free-standing version.

Mykonos

PG120P

an oasis of comfort and well-being

- Concealed and silent mechanism that ensures smooth operation of the system.
- Special water sealing system from the louvers to the base of the posts, which incorporates an effective water drainage system to protect against overflow due to heavy rainfall.
- Controlled conditions thanks to the adoption of bioclimatic logic and the incorporation of additional elements such as sliding glass and shutter systems, vertical shading rolling screens (ZIP), LED lighting, etc.
- State-of-the-art components such as the invisible patented silent rotation mechanism and automation systems.
- Wide range of solutions and possibilities for customization and extension to meet every need.



single wall-mounted

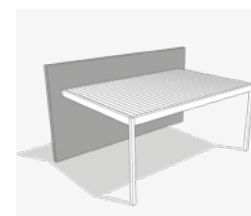

single wall-mounted with intermediate transom

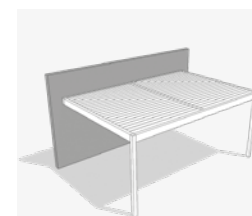

single free-standing

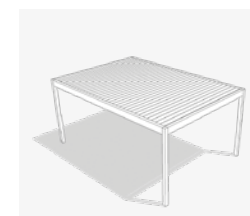

single free-standing with intermediate transom

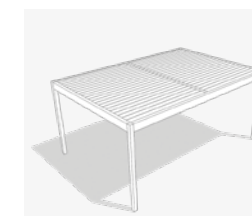

multiple free-standing

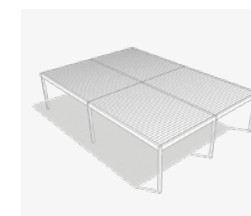

multiple free-standing with intermediate transoms

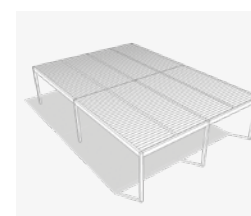

double wall-mounted with intermediate transoms

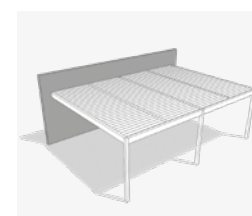

double free-standing

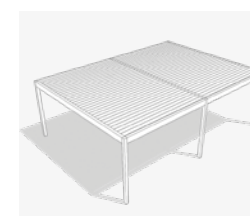

double free-standing with intermediate transoms

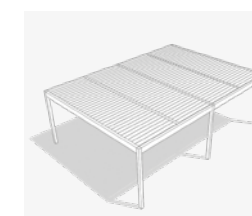

embedded



An ideal solution for outdoor areas in need of small or medium pergolas, ITHACA is easy to install thanks to its modular design as well as its lightweight construction, combining minimal aesthetics with effective shading and protection against severe weather conditions.

Ithaca

PG115P

essence through simplicity

- Minimal design and high aesthetics with straight lines, flat surfaces and almost invisible fixing points.
- Top sturdiness allowing single structures of relatively large dimensions without wind resistance problems (3.0m high by 4.0m wide & 5.0m projection, 20 sqm).
- High levels of water sealing and an effective drainage system that directs, through the posts, rainwater to the ground.
- Innovative rotation system, offering a nearly silent and smooth long-term operation.



single free-standing

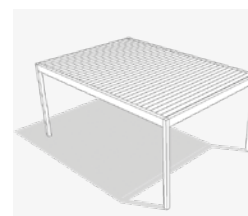

single wall-mounted

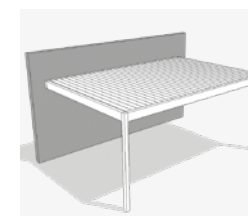

extra equipment

Advanced automation, special LED lighting, glass and shading systems (ZIP screens or shutters) are some of the additional elements that can be integrated into bioclimatic pergolas, making them even more functional and ensuring a comfortable life during the day and night.

Automation.

The following automation can be integrated into the bioclimatic pergolas, which are controlled via remote control or smartphone:

- Shading programming with automatic adjustment of slats during the day.
- Special sensor which closes the slats immediately in case of sudden rain or snow.
- Wind sensors to avoid damage in very strong wind conditions.
- Sound system with Bluetooth technology.
- Heaters mounted on the transoms.
- LED stripes on the louvers, controlled by the same remote control.



LED Lighting.

Dispelling the "myth" that pergolas are only used during the day, the integration of LED stripes allows you to create an atmospheric environment and enjoy unique moments of relaxation during the evening hours. You can choose between visible or concealed lighting, adjustable or not, on the louvers, around the transoms, or, in the case of MYKONOS, on the columns, extending the pergola's user experience and ensuring an elegant effect.

Glass System.

The perimeter cover of the pergola with a glass sliding system upgrades it aesthetically, creating the perfect protection from the wind without minimizing natural light. The glass systems incorporated into the pergolas are of top robustness and reliability, with high wind resistance and ensure stable conditions in the surrounding area. The following options are available:

- With a four guide rails system to provide 4 -sashes simple solutions.
- With a four guide rails system to provide 8-sashes meeting solutions.
- With a five guide rails system to provide 5-sashes simple or meeting solution (PG120P Mykonos only).

ZIP screen shading system.

Thanks to the advanced ZIP technology, the shading system is particularly durable, acts as additional shading around the perimeter of the pergola, offers effective protection on rainy days and allows large dimensions of up to 6 m. Specially designed and almost invisible, the system parts do not affect the overall minimal aesthetics. The rolling ZIP screen can be combined with a fly-screen for effective protection against insects, but also with a glass sliding system on the same side, further expanding the possibilities for personalizing the pergola.

color index

Combine pre-anodizing with the unlimited powder coating colors offered, creating architectural solutions of unparalleled beauty, incomparable quality and long-lasting durability.



Color Index of super durable powder coating.

Usually, pergolas are placed in coastal areas and next to swimming pools, where salt and chlorine cause erosion. By combining Seaside Class powder coating with the special pre-anodizing surface treatment procedure, GLM is able to effectively prevent the occurrence of "filiform" corrosion.

super durable powder coating

super durable
matt colors
(class 2)

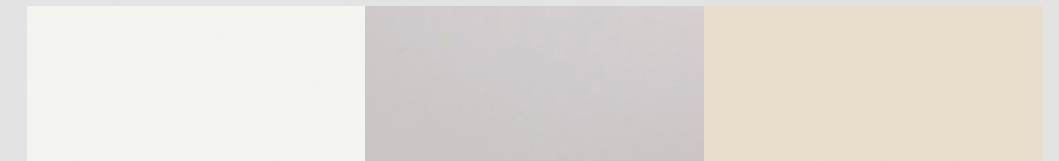

RAL 9016 MATT
D2525 - YA216F

RAL 9006 MATT
D2525 - YW206F

RAL 1013 MATT
D2525 - YD813F

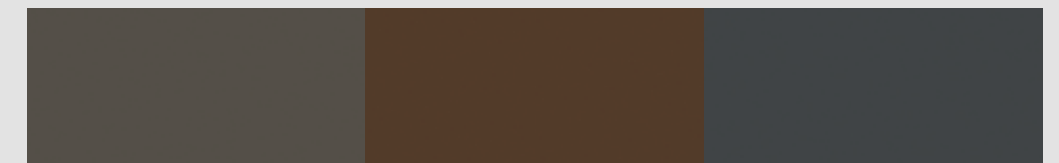

RAL 7022 MATT
D2525 - YL280F

RAL 8014 MATT
D2525 - YM257F

RAL 7016 MATT
D2525 - YL2216F

super durable
textures colors
(class 2)



RAL 9016 STRUCTURA
YA316F

RAL 9006 STRUCTURA
Y2328F

RAL 1013 STRUCTURA
YD313F



RAL 7022 STRUCTURA
YL322F

RAL 8014 STRUCTURA
YM314F

RAL 7016 STRUCTURA
YL316F

fixed pergolas

GLM offers a complete range of fixed pergolas, which includes four different models (CRETA, CORFU, KOS & NAXOS) in modern and traditional lines that satisfy every aesthetic preference. All fixed pergolas offer highly effective shading while contributing to the enhancement of outdoor spaces.

Creta



Corfu



Kos



Naxos



Their top robustness and unrivalled ease of installation make them ideal for residential exteriors as well as hotels, dining and recreation areas.

- Minimal aesthetics with clean design lines and concealed fixation points.
- Top robustness and impressive wind resistance, allowing for large dimensions (up to 6x4m for Creta).
- Excellent durability without corrosion problems in coastal areas.
- Unrivalled easy and quick installation, with lightweight elements and a simple assembly process.
- Possibility of customization by applying and combining additional elements such as aluminium blinds, polycarbonate or glass panels, shading fabrics, natural or synthetic wood, reeds, etc.
- Numerous colour options.



CRETA is the basic proposal of the fixed pergolas series. These are pergolas of unparalleled aesthetics and top robustness that can withstand high wind loads and limit sway, even when shading or rain protection elements such as fabrics and panels are installed. Most of the work is carried out in GLM's factory, making installation on-site quick and easy.

Creta

the epitome of minimal aesthetics

- Special design with hook-type connectors for fast and easy installation of both the framework and the louvers, which can be mounted like framed panels.
- Possibility of various complex constructions (corner, multiple etc.).
- Selection between various aluminium louvers (i.e. 20x15mm, 35x130mm).
- Possibility of applying additional elements such as shading fabrics, wood composite louvers or vertical shutters for an unparalleled aesthetic result.
- Maximum pergola dimension 6x4m.



CORFU stands out for its modern and imposing design, which differs significantly from the classic wooden constructions. It is an alternative proposal for a fixed pergola that offers effective shading while upgrading the aesthetics of the surrounding area.

Corfu

an exceptional modern proposal

- Use of 120mm post without visible fixation points.
- Special hook-type connectors for robustly connecting transoms with mullions.
- Possibility of applying additional elements such as aluminium or wood composite louvers, shading fabrics etc.
- Maximum pergola dimension 4,8x6m.



The KOS model is a fixed pergola that also offers effective protection from rain, which is achieved through the use of overlapping aluminium louvers. Thanks to the special design, a sealed roof with sufficient ventilation and lighting is created, with rainwater being guided to the ground through the posts.

Kos

elegance & effective rain protection

- Effective shading and protection from rain.
- Integrated natural ventilation and drainage system.
- LED lighting.
- Top robustness allowing for large constructions (6x 2.6m).
- Modular design that facilitates placement on the project site.
- Possibility of combination with the fixed pergola CRETA and the rotating bioclimatic MYKONOS.
- Possibility of extending the projection with 6 posts (11.8x2.6m).

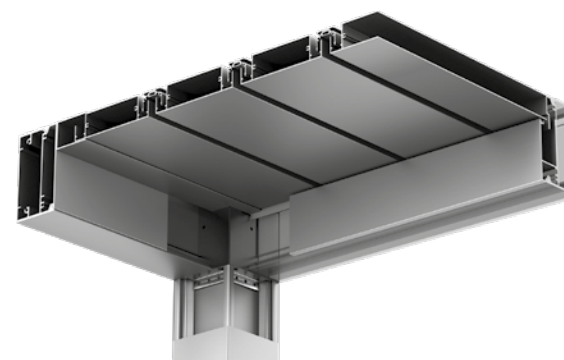

Inspired by Cycladic architecture, NAXOS offers fixed pergolas of top quality and durability, with traditional design and the timeless aesthetics of wood. Redefining tradition, NAXOS is the ideal choice for modern residences or hotels with a traditional or island aesthetic.

Naxos

traditional design with timeless value

- Effective shading.
- Top sturdiness that allows for large 5x5m constructions.
- Modular design that facilitates placement on the project site.

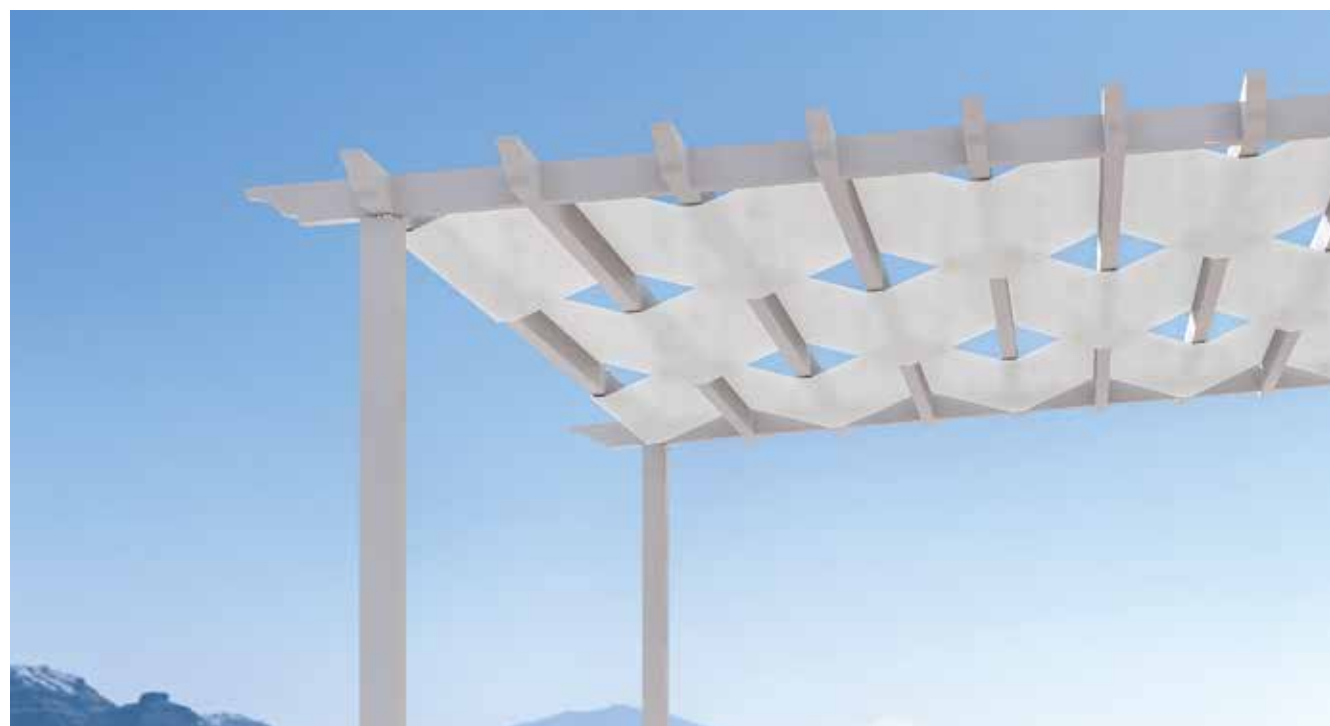

fencing systems

GLM offers two minimal fencing systems, with louvers either placed in-between mullions (FC80) or attached to them (FC60), with clear lines and concealed fixing points.

FC80



FC60



Robust and reliable, the fencing systems are maintenance-free, ideal for modern residential or hotel facilities and available in standard or customized solutions, with a variety of designs to suit every architectural need.

- A wide variety of design patterns and unlimited possibilities for personalization.
- Top robustness without problems of damage to the structure from wind load and strong weather conditions.
- Possibility of large dimensions, especially for gates, to allow for easy pass-through of vehicles (up to 6m.)
- Unparalleled aesthetics, design with attention to detail, 100% aluminium constructions.
- Innovation with new styles, modern materials and smart combinations for unique constructions.



An advanced and multiform fencing system that offers a multitude of technical solutions and applications and is a valuable tool for every project and need. The main system's features are the inlaid installation of the infills between the posts and the vast range of decorative materials applied. In addition, the system stands out for its incomparable sturdiness, with reinforced profiles and heavy-duty components to allow for greater distance between columns, construction of privacy fencing and larger gate dimensions.

FC80

define your outdoor space through unique decoration

- Top robustness for very large structures, especially for gates, to ensure comfortable passage of vehicles (up to 6m.)
- Ability to construct "blind" surfaces without problems with wind load (over 2m high).
- Wide range of proposed solutions and great scope for customization, thanks to the variety of profiles and technical solutions.
- Innovation and differentiation through the use of innovative materials, smart frames, lighting options, oversizing etc.
- Replacement of concrete structures (mullions, shading) with aluminium profiles.



Use of pivot hinges and posts 120mm or 250mm, for large gates panels and 100% aluminum result (without concrete posts).



Multiple LED lighting options along the louvers, posts, handrails, handle, etc.

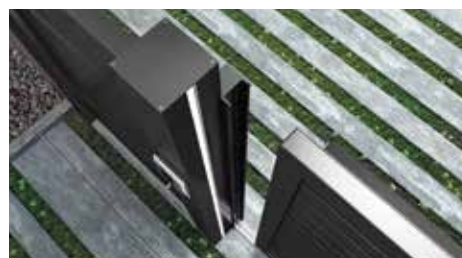

Sliding gate is available as an alternative to the hinged gate (with one or two leaves), offering top reliability and full automation.



Variety of decorative post caps (pyramid, triangle or flat style) available in long-lasting colors.

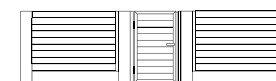

fence/single leaf/fence

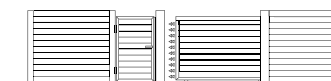

fence/single leaf/double leaf/fence



fence/single leaf/double leaf/fence



A complete aluminium fencing system with the selected louvers attached to the mullions. It offers a continuous linear design effect, complements the aesthetics of the surrounding areas and is highly recommended for hotels and residences. The system is characterized by high robustness, allowing for large construction dimensions, and offers all gate options, single, double-leaf hinged and sliding).

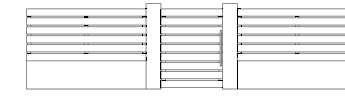

fence/single leaf/fence



fence/double leaf/single leaf/fence

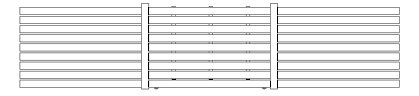

fence/sliding gate/fence

FC60

a highly aesthetic fencing system

- Top design with a simple, linear aesthetic, without visible fixing points.
- Wide range of solutions and design proposals, especially in aluminium louvers.
- Unique combinations with composite wood materials, such as WOODALUX hybrid louvers.
- Top robustness and possibility for very large constructions.
- Special design for ease of construction.

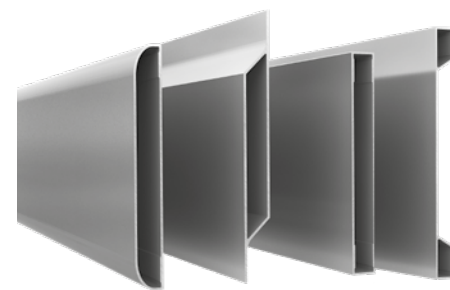
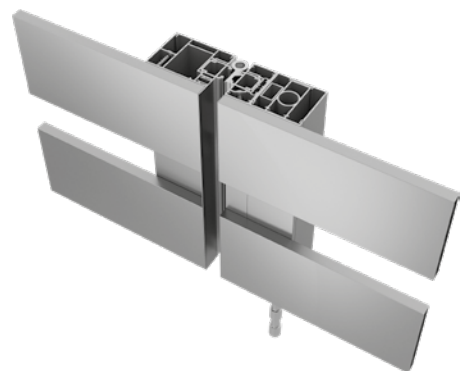

color index

Combine pre-anodizing with the unlimited powder coating colors offered, creating architectural solutions of unparalleled beauty, incomparable quality and long-lasting durability.



Color Index of super durable powder coating.

Usually, pergolas are placed in coastal areas and next to swimming pools, where salt and chlorine cause erosion. By combining Seaside Class powder coating with the special pre-anodizing surface treatment procedure, GLM is able to effectively prevent the occurrence of "filiform" corrosion.

super durable powder coating

super durable
matt colors
(class 2)

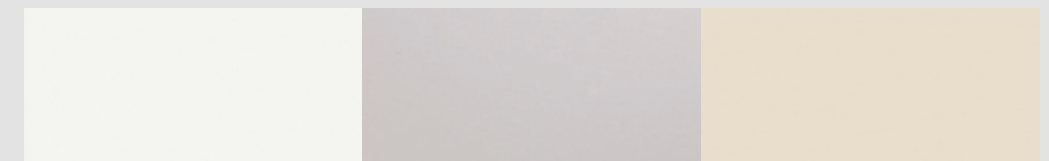

RAL 9016 MATT
D2525 - YA216F

RAL 9006 MATT
D2525 - YW206F

RAL 1013 MATT
D2525 - YD813F



RAL 7022 MATT
D2525 - YL280F

RAL 8014 MATT
D2525 - YM257F

RAL 7016 MATT
D2525 - YL2216F

super durable
textures colors
(class 2)

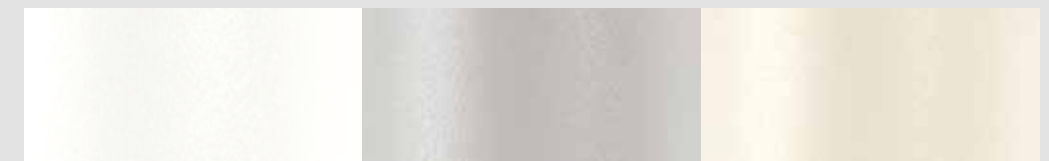

RAL 9016 STRUCTURA
YA316F

RAL 9006 STRUCTURA
Y2328F

RAL 1013 STRUCTURA
YD313F



RAL 7022 STRUCTURA
YL322F

RAL 8014 STRUCTURA
YM314F

RAL 7016 STRUCTURA
YL316F



HEADQUARTERS & FACTORY

Kilkis Industrial Area , Block 11
PO box 19, Kilkis PC 61100

T: +30 23410 71100
E: pergolas@glmhellas.com



Explore all of our outdoor
solutions at glm-outdoor.com



@glm_hellas



@GLM.OutdoorSolutions



GLM Outdoor Solutions



